

BIKE RACK INFORMATION:

1. REPLACEMENT BIKE RACK SWING ARMS WILL BE SOLD FOR THE FOLLOWING VEHICLES: FORD E-SERIES VAN, FULL SIZE TRUCKS, AND SPRINTER (CONTACT US FOR SPRINTER REPLACEMENT). THE COST OF THE SWING ARM IS \$650 WITHOUT THE BIKE RACK TRAYS OR BOX.
2. ALUMINISS RECOMMENDS THE SWING ARM BE INSTALLED WITH 1UP-USA'S BIKE RACK TRAYS. THEY ARE AVAILABLE FOR PURCHASE FROM US WITH NECESSARY HARDWARE FOR EASY INSTALLATION FOR \$239 EACH (MAXIMUM 2 INSTALLED). OTHER BIKE RACK TRAYS MAY WORK WITH OUR PLATFORM, BUT HAVE NOT BEEN TESTED. THEREFORE, NO WARRANTY IS AVAILABLE WITH OTHER BIKE RACK MOUNTS.
3. THE MAXIMUM WEIGHT THAT THE BIKE RACK SWING ARM CAN CARRY IS 100 LB ON THE BOTTOM MOUNTS (LABELED "BM")AND 100 LB ON THE UPPER MOUNTS (LABELED "UM"). THIS WEIGHT DOES NOT INCLUDE THE WEIGHT OF THE BOX OR BIKE RACK TRAYS. **LOADING MORE THAN 100 LB ON THE BOTTOM AND 100 LB ON THE TOP OF THE SWING ARM OVER-STRESSES THE MATERIAL AND VOIDS ANY WARRANTY!**
4. THE SWING ARM HAS BEEN DESIGNED TO FIT OUR GALLEY BOX (WITH OR WITHOUT RAILS) OR DELUXE BOX (WITHOUT RAILS ONLY). MOST PRE-OWNED BOXES ARE TRANSFERABLE - SEE DRAWING BELOW FOR MORE DETAIL.
5. THE SWING ARM WITH BIKE RACKS INSTALLED HAS BEEN DESIGNED TO WORK WITH TIRE SIZES UP TO 35" IN DIAMETER.

MEASUREMENT INSTRUCTIONS FOR REPLACEMENT SWING ARM WITH BIKE RACK CARRIER:

1. FILL THE TABLE BELOW WITH REQUESTED INFORMATION AND DESIRED POSITION OF THE BIKE RACK (PASSENGER/DRIVER).
2. MEASURE YOUR CURRENT SWING ARM TO OBTAIN MEASUREMENT "A". MEASURE FROM THE TOP SURFACE OF THE LOWER ROTATING HINGE, TO THE BOTTOM SURFACE OF THE UPPER ROTATING HINGE (**INSIDE TO INSIDE**). MEASUREMENT SHOULD BE TO CLOSEST 1/16" OR 1/32" IF AVAILABLE.

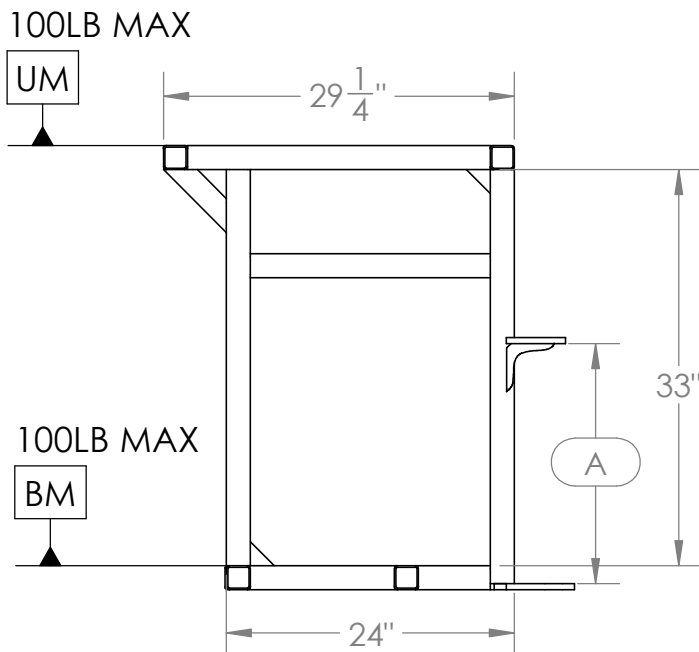

BIKE RACK SWING ARM INFORMATION	
CUSTOMER NAME:	
MAKE:	
MODEL:	
YEAR:	
PASSENGER/DRIVER:	
"A"	

CUSTOMER VERIFICATION OF INFORMATION AND DIMENSIONS:

SIGNATURE: _____ DATE: _____